

Module HC 144

450-460 Watt

Positive power tolerance of 0~+3%
HALF CELL - MONO PERC 144 CELL



ISO9001:2015 certified factory UL61730 certified product

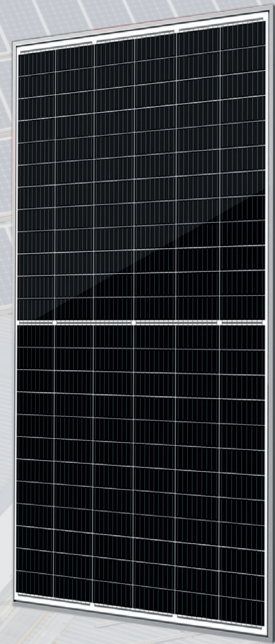

KEY FEATURES



Multi Busbar Solar Cell

Multi busbar solar cell adopts new technology to improve the efficiency of modules, offers a better aesthetic appearance, making it perfect for rooftop installation.



High Efficiency

Higher module conversion efficiency (up to 20.97%) benefit from half cell structure (low resistance characteristic).



PID Resistance

Excellent Anti-PID performance guarantee limited power degradation for mass production.



Low-light Performance

Advanced glass and cell surface textured design ensure excellent performance in low-light environment.



Severe Weather Resilience

Certified to withstand: wind load (2400 Pascal) and snow load (5400 Pascal).



Durability Against Extreme Environmental Conditions

High salt mist and ammonia resistance.

ENGINEERING DRAWINGS

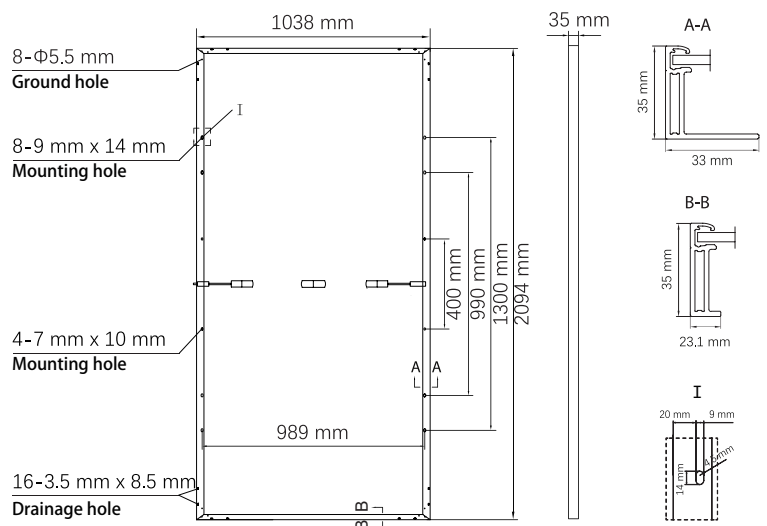

PACKAGING CONFIGURATION

(Two pallets = One stack)

31pcs/pallet , 62pcs/stack, 775pcs/53FT Truck

LINEAR PERFORMANCE WARRANTY

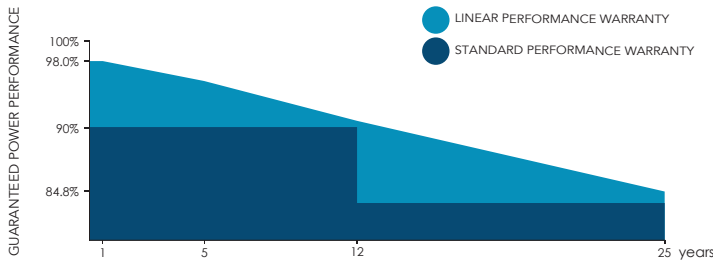

12 Year Product Warranty

25 Year Linear Power Warranty

MECHANICAL CHARACTERISTICS

Cell Type	Mono PERC 166x83mm
No. of Half-cells	144 (6x24)
Dimensions	2094x1038x35mm (82.44x40.86x1.37 inch)
Weight	23.0 kg (51.8 lbs)
Front Glass	3.2mm, Anti-Reflection Coating, High Transmission, Low Iron, Tempered Glass
Frame	Anodized Aluminium Alloy
Junction Box	IP68 Rated, connector compatible with MC4
Output Cables	TÜV 1x4.0mm 450mm/1200mm or Customized Length
Fire Rating	UL: Type 1, IEC: Class C
Maximum static load	5400Pa (front side), 2400Pa (back side)

ELECTRICAL PERFORMANCE & TEMPERATURE DEPENDENCE

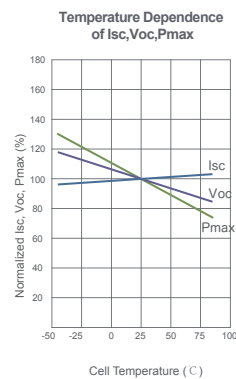
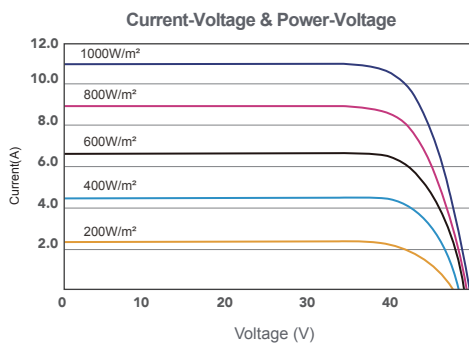

SPECIFICATIONS

Module Type	SE-166*83-450M-144	SE-166*83-455M-144	SE-166*83-460M-144
	STC	STC	STC
Maximum Power (Pmax)	450W	455W	460W
Maximum Power Voltage (Vmp)	41.32	41.51	41.7
Maximum Power Current (Imp)	10.89	10.96	11.03
Open-circuit Voltage (Voc)	49.05	49.35	49.62
Short-circuit Current (Isc)	11.37	11.44	11.51
Module Efficiency STC (%)	20.7%	20.9%	21.2%
Operating Temperature (°C)		-40°C ~ +85°C	
Maximum System Voltage		1500VDC (IEC)	
Maximum Series Fuse Rating		20A	
Power Tolerance		0~+3%	
Temperature Coefficients of Pmax		-0.35%/°C	
Temperature Coefficients of Voc		-0.29%/°C	
Temperature Coefficients of Isc		0.048%/°C	
Nominal Operating Cell Temperature (NOCT)		45±2°C	

STC: Irradiance 1000W/m²

Cell Temperature 25°C

AM=1.5

NOCT: Irradiance 800W/m²

Ambient Temperature 20°C

AM=1.5

Wind Speed 1m/s

*Power measurement tolerance: ± 3%

Contact us!

Become the best solar company for the world +1(956) 962 2969 accounts@solareverusa.com